

# **DATATOOL EVO PLUS ALARM WITH SINGLE CIRCUIT IMMOBILISATION INSTALLATION GUIDE**

**IMPORTANT:** This manual is designed to provide fitting instructions to competent, trained installers who are familiar with automotive electronics. If you are not a person that matches this criteria, do not attempt installation and instead contact your local Datatool Authorised Dealer for assistance. Scorpion Automotive Ltd accepts no responsibility for any injuries or damage caused from installation by untrained or unqualified installers.

Due to the sensitive nature of its contents, Scorpion Automotive Ltd specifically forbids any part of this Installation Guide from being copied, reproduced and transmitted or distributed to any third party without the prior permission in writing of Scorpion Automotive Ltd.

Any person(s) found to be in breach of this may find themselves subject to prosecution.

© Scorpion Automotive Ltd 2021.

# 1. KIT CONTENTS

1x Alarm ECU with interconnecting wiring and plug.

Dimensions of the alarm are: Length: 111.7mm Width: 60.2mm Height: 33.7mm

*(max. housing dimensions)*

1 x Alarm

1 x Fuse Holder

1 x 10amp Fuse

1 x Wiring Harness with Connecting Plug and

Black Wires with Identification Tags fitted

2 x Remote Controls

1 x Pin Code Foil

1 x LED Bezel with Plug

1 x Magnet switch

1 x Protective Seat/Panel Switch with Plug

6 x Cable Ties

2 x Single Sided Adhesive Pads

1 x Indicator Diode

1 x User Guide

## 2. TOOLS REQUIRED

The following tools may be required to correctly install the system. Please note that the list includes a voltmeter – Test lights and Test Bulbs should not be used as an alternative.

- Socket set and/or Spanners
- Wire Strippers
- Wire Cutters
- Soldering Iron and Solder
- Insulation Tape
- Trim Tool
- Small and Medium-Sized Philips Screwdrivers
  
- Torx and Hex Drivers
- Small and Medium Flat Blade Screwdrivers
- Heat Gun or Similar
- Electric Drill
- Drill Bits – 2.5mm, 8mm
- Voltmeter

### 3. SPECIFYING THE SYSTEM

It is critical the correct alarm system is chosen to suit the customers' requirements. Please note that this system is not an insurance-approved product, if insurance approval is an important criteria for your customer then you should look to install a Datatool S4 Series alarm or equivalent. Scorpion Automotive Ltd cannot be held responsible for incorrect choice of product or costs incurred removing an incorrectly specified alarm.

If you require further assistance in choosing the correct alarm system then please contact [info@datatool.co.uk](mailto:info@datatool.co.uk) with details of the motorcycle/scooter requiring the alarm.

This alarm system is intended for use on motorcycles or scooters, with or without a factory immobiliser system. The Datatool Evo Plus has the following specification:

- Single engine immobiliser circuit – suitable for use on 'normally open' or 'normally closed' vehicle circuits
- Movement sensor (3 level adjustment)
- Panic facility via remote control
- PIN override (factory set, non-adjustable) suitable for key or keyless ignition vehicles
- Check status LED
- Seat/panel switch
- Automatic arm / re-arming (Selectable, re-arms alarm if disarmed by remote and ignition is not switched on)
- Arm/disarm chirps (Selectable when arming or disarming)
- Bike finder via flashing indicators or side lights (depending on installation)
- Additional negative output to trigger secondary device (e.g. pager)
- System memory (remembers the last state in which it was left if the battery is disconnected)

### 4. CONFIGURING THE ALARM TO SUIT THE CUSTOMERS' REQUIREMENTS

Due to the design of the EvoPlus series it is possible to configure the system in several ways. It is advisable to discuss the options available with the customer prior to installing the system. Some of the features

may not be applicable to certain markets due to local regulations (e.g. arm/disarm audible notifications).

First select the type of security system the customer requires and then discuss any specific requirements the customer may have (e.g. LED position, automatic re-arming etc.).

## **5. PRE-INSTALLATION CHECKS**

- Never install an alarm to a machine you have not checked out electrically and heard running.
- Always carry out a full visual inspection of the machine prior to installation, particularly if the machine is second hand or has been brought in for an alarm to be installed. Any faults or damage discovered should be reported to the owner or their agent prior to carrying out the installation of the system.
- The battery for the machine should be checked for full charge prior to installation. If it is found to be low it is advisable to place it on charge. The Datatool Smart Charger battery conditioner will bring the battery up to full charge safely in the minimum time. Should the battery be in a poor state, it is strongly advised the customer is informed the battery needs replacement as the alarm, although only drawing around 4mA, will increase the loading on the battery.

## **6. STRIPPING THE MACHINE**

- Always take extreme care when removing and storing panels from the machine to ensure they do not get damaged.
- Always note the size, type and position of any fixing you remove. It is very easy to forget what goes where.
- Should a panel prove difficult to remove, take a further look to ensure the strip sequence is correct and that all fixing devices have been removed (it's very easy to miss that little hidden clip).

## **7. PLANNING THE INSTALLATION**

The alarm components should be located to ensure the maximum time is required for the thief to access the system. Other factors such as the storage of customer's personal belongings and other equipment such as intercoms, chain oilers, etc. should also be considered.

Always plan the physical position for all the alarm components prior to installation. If there is any doubt on panel fit, ALWAYS temporarily mount the unit and refit the panel prior to wiring the alarm. Once the alarm has been installed it may be impossible to move the position to a new location. A few moments spent checking at this point can save several hours of re-working.

### Cable Tie Mounting Technique

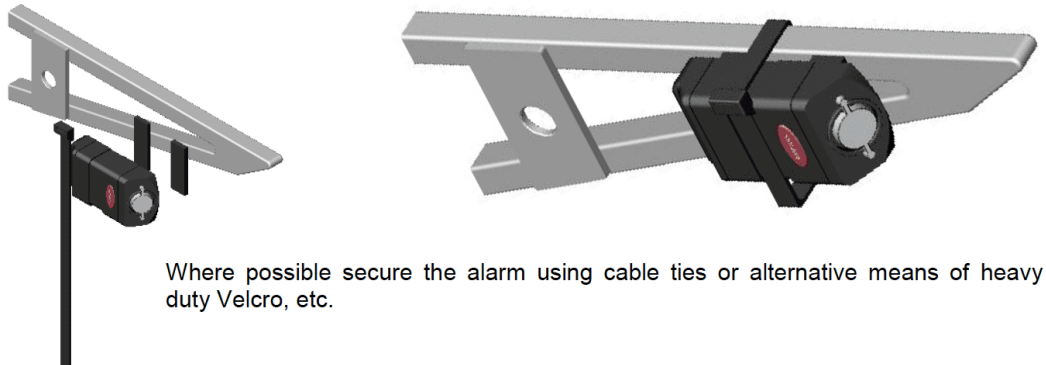

## LED MOUNTING METHODS & POSITION

Where possible the position of the system LED should be agreed with the owner prior to installing. The LED is the effectively first line of protection and should be mounted in a highly visible position to ensure maximum deterrent effect. Installation options are shown below:

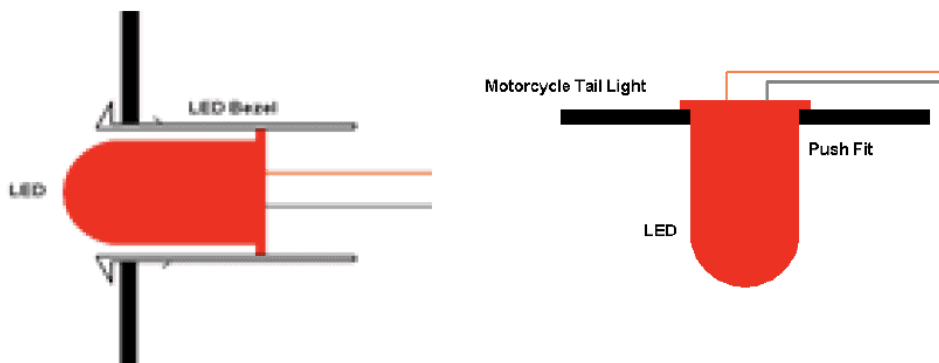

The LED with Bezel may be mounted through an inner fairing panel or even mounted through a light lens into a tail light unit. Warning: When fitting into an LED tail light take care not to damage the internal rear light circuit board.

## 8. PLANNING THE WIRING

Where applicable, the method of immobilisation for the machine should be selected and the wiring configured accordingly.

Access the wiring harness at the most suitable place(s) and identify the wires you are going to connect to using suitable safe test equipment. Analogue meters and bulb based test lights are low resistance and can easily damage delicate electronic units fitted to some machines. It is advisable to use high resistance test equipment (e.g. Digital multi-meters, LED based test lights {logic probes}, LCD testers). If you have doubts regarding the suitability of your test equipment, please refer to the manufacturer's workshop manual.

Once the alarm wiring points have been selected, construct the alarm harness accordingly. When constructing the alarm loom pay close attention to the positioning of the alarm plugs in relation to each other. It is advisable to temporarily connect the alarm harness to the alarm at this stage to correctly align and tape or heat-shrink the harness together whilst constructing the harness. Failure to do this may mean the plugs cannot be easily connected between the alarm and the harness.

Please note the alignment of the plugs in the image, the harness should be constructed so the flat sides of the plugs are placed together (i.e. clasps outwards).

When routing the alarm harness it is advisable to run it alongside or within the original wiring harness of the machine and loom/sleeve it in a similar manner to the original harness where possible. The loom must be protected from any sharp edges likely to cause damage to the harness.

### Connection Methods

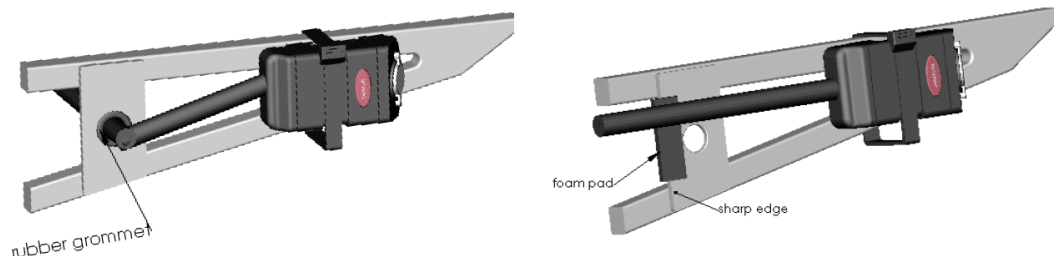

We recommend that soldered joints are used for all connections which when made are fully insulated with a suitable tape, the use of Scotchlocks must be avoided at all costs.

Any unused wiring should be removed or taped up and securely fastened to the bike.

## 9. WIRING CONNECTIONS

The Datatool Evo Plus motorbike alarm system is designed to work on 12 volt negative earth electrical systems only. Do not install this product to a positive earth machine.

The main positive and negative connections are the most important wires of any alarm system as they supply the power to make most of the other functions work.

### **Main Positive Supply (red tagged wire)**

The red tagged wire is the main power supply to the alarm and requires a permanently live 12v positive feed.

Many machines are now equipped with a dedicated permanent 12 volt positive feed designed to power an alarm system. Alternatives can be the clock or fan fuse. The rating of this fuse should be no more than 10amps. If the rating is below this the fuse may blow when indicators flash via the alarm system.

The alarm is equipped with internal protection to deal with shorts on the indicators but it is always advisable to fit a protection fuse as this protects the wiring from the fuse to the alarm unit itself. Where possible the fuse should be fitted as close as possible to the source of power. The supply should never be taken directly from the battery.

### **Main Negative Supply (black tagged wire)**

This wire can be on the frame or within the wiring harness but should never be taken directly to the battery. Any harness based earth should be tested to ensure it is a true earth and does not change when the ignition is turned on and switches are operated. If unsure refer to the machine's wiring diagram.

We advise the use of harness based earths in most cases. Frame earths, especially on anodised frames, can be very poor.

### **Main ignition switched connection (brown tagged wire)**



This wire needs to be connected to an ignition switched supply that stays live even when the starter is cranking the engine otherwise the immobiliser circuit when connected may not function correctly.

### **The Engine Cut (white and white/red or white and white/green wires)**

There are two main methods of immobilising a machine, the first and most common is by cutting a wire which is essential to the running of the machine (DC cut method), the second is by earthing out a signal wire so the ignition system cannot create the spark needed for the engine to run (AC 'earth out' method). Whichever method is used the immobilisation point should be made as inaccessible as possible. One immobiliser wire on the alarm harness will always be unused depending on the method of immobilisation and this wire should be removed completely.

#### **DC Cut Method**

– For DC cut use white wire and white/green wire

Identify a wire which is critical to the engine operating but which is carrying less than 7 amps and cut it. With modern machines it is normally wise to use either the dedicated immobilisation points provided by the manufacturer or to use an engine safety interlock (e.g. side stand switch, kill switch, fall over sensor, etc.). Other circuits, such as the fuel pump relay, ignition pack or coils may be used but refer to the manufacturers service manual before using these circuits as they may cause the machine to log error codes.

Where possible remove a section of the original cable and re-join this wire via the white and white/green wire. These wires are non-directional so it doesn't matter which wire of the alarm is connected to which end of the cut wire.

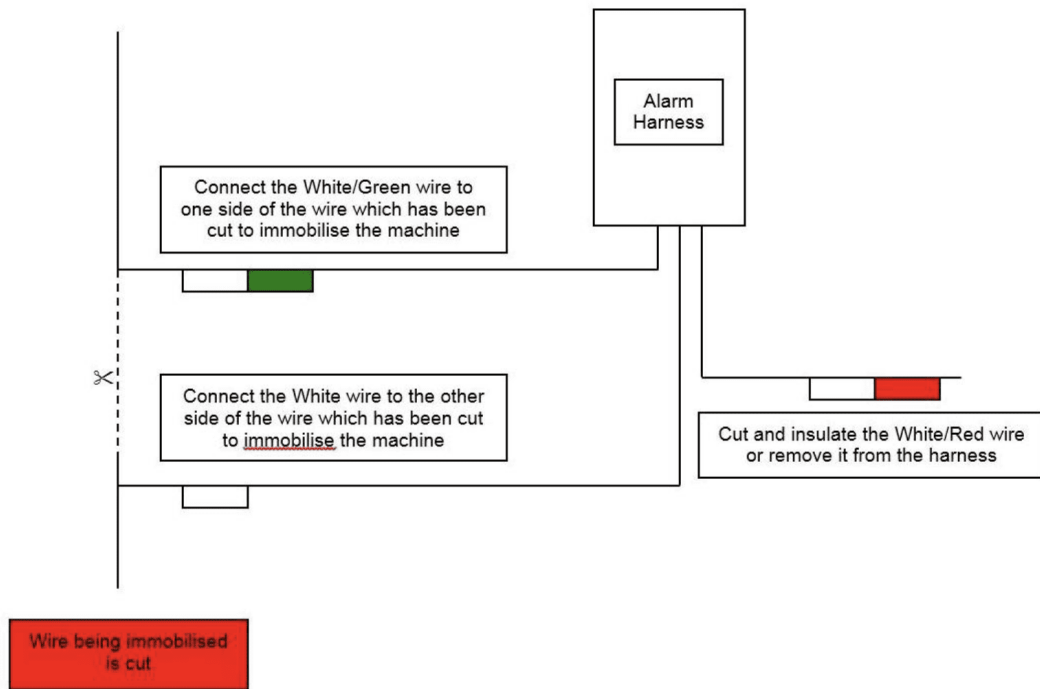

Important notice: On CANBUS based machines it is recommended that the only circuit cut is the wire between the kill switch and the ECU. Other points of immobilisation are likely to create fault codes. Most CANBUS based machines are equipped with a transponder immobiliser as standard

### AC Method

– For AC cut use white wire and white/red wire

Identify the wire which when earthed out stops the ignition pack creating a spark. This wire normally runs from the ignition switch and/or kill switch to the ignition pack and will have an earth on it when the machine is not running and be isolated, have a minimal earth on it or be pulsing when the machine is running.

Connect either the white or white/red wire to a suitable good earth supply and the remaining wire to the engine kill wire.

When the immobiliser circuit is armed the engine kill wire will be earthed out via the immobiliser circuit and hence will not run.

Please note: Whilst this method of immobilisation works it is not as secure as the DC immobilisation above. Datatool recommend the DC immobilisation method is used where possible (even on AC type machines).

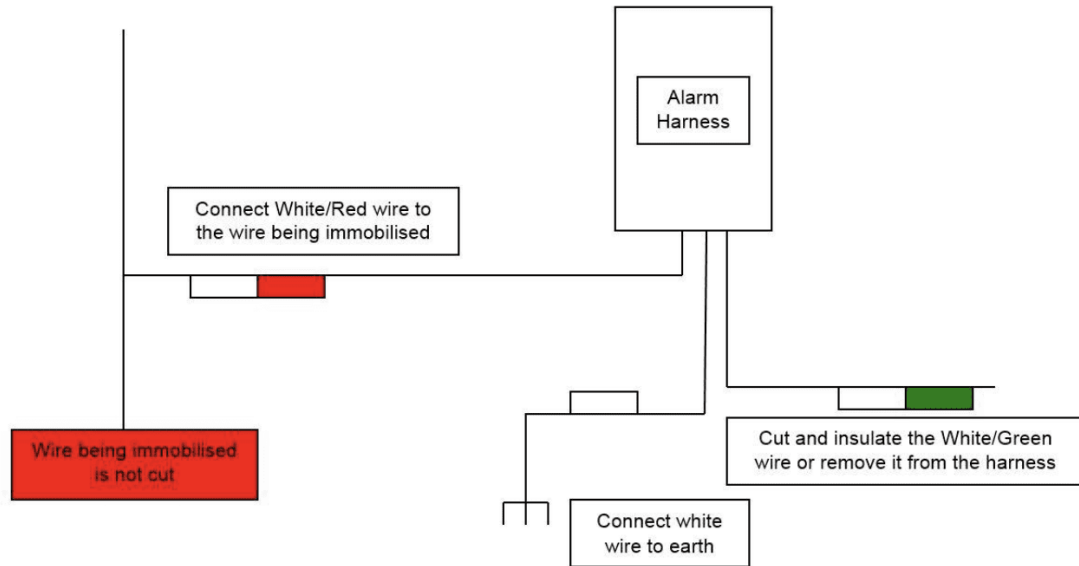

### The 12 volt Ignition Switched Supply (brown tagged wire)

This wire stops the alarm from arming when the ignition is turned ON.

It is important the wire remains positive when all the machines controls are operated. Should the power fall away from this wire it is possible the engine may cut out. For this reason we advise you connect to an ignition switched positive supply which is run critical. In this way if the power to this wire fails the machine would stop anyway and therefore supply taken becomes as safe as the machine itself.

One exception to this is using a kill switched controlled ignition supply. This is acceptable but it must be explained to the customer that the immobiliser will arm if the kill switch is turned to off.

Many installers use other circuits (e.g. the rear brake light supply). Whilst this will work it should be realised if the fuse blows to this circuit due to a fault on the machine itself the machine would stop. As the blown OE fuse is not related to the running of the machine in the standard form, it may be difficult for the customer to identify why the machine has stopped.

On some machines certain ignition switched positive circuits turn off whilst the starter button is being operated to reduce the load on the battery. This is particularly true of lighting circuits, therefore it is

important to ensure the chosen 12v switched feed stays live when the engine is cranking.

Should you choose to take your 12v switched feed from the same circuit that is being used to immobilise the machine it is important you ensure the switched feed is taken prior to the immobiliser cut. If the switched feed is taken after the immobiliser cut (i.e. the 12v switched feed is interrupted by the immobiliser) the alarm will not commission and the bike will not start.

On certain machines with CANBUS electrical systems, there may be a slight delay between the ignition being switched off and the chosen switched feed dropping to zero volts. This is quite normal on this type of machine and simply delays the arming period of the alarm by the time it takes for the ignition control relay of the machine to reset. If the machine has this feature most manufacturers recommend the ignition is not turned back on until after the ignition has automatically reset. With these types of electrical systems, turning the ignition OFF and then immediately back ON may in extreme circumstances cause error codes to be recorded on the machine. If you are unsure please refer to the manufacturer's manuals.

### **Indicator Connections (1x pink and 1 x pink/red tagged wires)**

The Datatool Evo Plus alarm provides visual indication of arm/disarm and alert by providing a 12v positive feed on both the pink and pink/red tagged wires intended to be connected to the indicator circuits. It is important on machines fitted with LED indicators that the voltage at which the indicators operate (i.e. the voltage the machine provides to the indicators) is ascertained before making any connection to the indicator circuits. Some motorcycles are now using 5v LED indicators which will be permanently damaged if connected to the 12v feed provided by the alarm.

The alarm system should be connected to the left and right indicator positive feeds. Do not connect to the negative wire of the indicator and do not connect to the indicator relay output. On some machines you may only be able to make the rear or front indicators operate without the inclusion of extra diodes into the indicator outputs of the alarm system. If you are unable to power the indicators without

damage, it may be an option to power the sidelight and/or tail light according to the customer preference.

## The Indicator Diode Test

Some machines require an in-line diode to be installed into the wiring of the indicator circuit. To determine if this is required, carry out the following test after installing the alarm:

- With the ignition turned OFF, position the indicator switch of the machine so it would be set to flash the indicators either right or left, it doesn't matter which way.
- Position the light switch of the machine (if fitted) so the lights would be on if the machine was running.
- Arm or disarm the alarm whilst looking at the dash lights and instruments to see if anything other than the indicator repeater lights works. If this happens with the indicator set to left or right; a diode is required.
- Arm or disarm the alarm and check to see if the headlight or side light illuminates.
- Test the starter button to see if the machine cranks (always check the machine is in neutral and any interlock systems on the machine are set to the run position, e.g. kill switch, clutch, side stand, etc.).
- If during these tests any extra lights or instruments operate, the alarm fuse blows or the machine cranks over, a diode will have to be inserted in line with the input or output of the indicator relay.

## Dioding the Indicator Relay

The diode can be fitted in either the feed to the relay from the fuse box or the output from the relay to the indicator switch, it doesn't matter which as long as it is connected the correct way round.

The input wire will be an ignition switched positive from the fuse box to the indicator relay. If this wire is cut the band on the diode should face towards the relay

The output wire is the feed to the indicator switch which provides the pulsed output to flash whichever side indicators are selected via the

switch. When this wire is cut the diode is positioned with the band facing away from the relay.

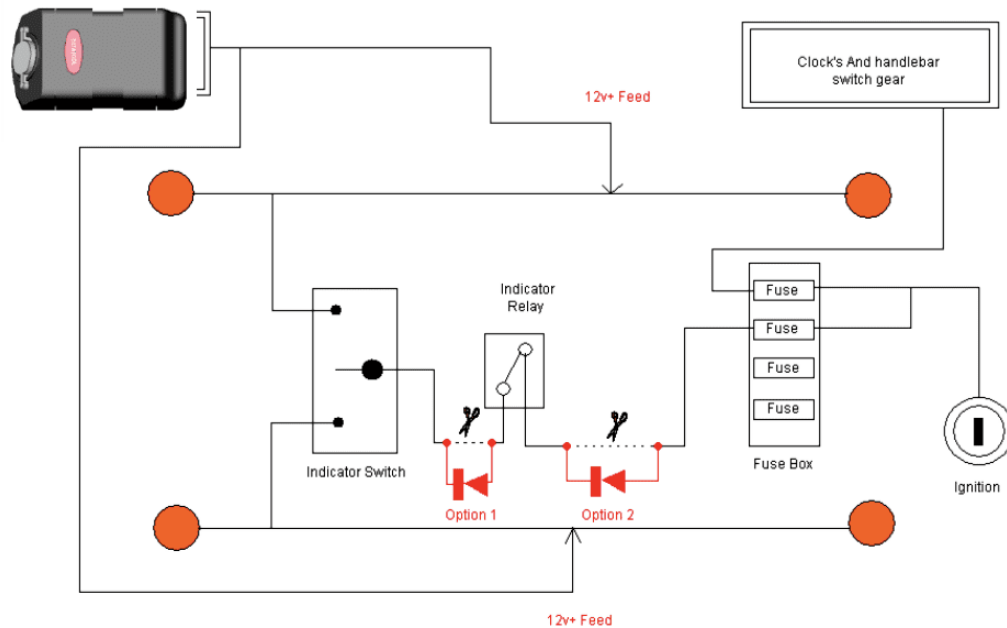

If you are unsure which way to fit the diode, cut the selected wire; hold the diode in line and with the ignition on set the indicator to the left or right. If the indicators work normally, you have got it the right way round. If they do not operate, reverse the diode and test again. Once you have it the right way round, solder it in line and protect the joints with heat shrink or good quality tape.

### Alarm Protection Switch (black and green/red wires)

The kit comes supplied with a magnetic reed switch for this purpose. Other switches such as micro switches can be substituted if required.

The switching arrangement is change of state. The green/red wire is the trigger line and the black wire is an earth supplied from the alarm plug. When armed if the earth is applied or removed from the green/red wire the alarm will trigger.

Fit the magnetic reed switch so the alarm would be triggered by the removal of a seat or body panel before the alarm ECU is accessed.

Choose an area where the switch and magnet can be placed in close proximity to each other. When correctly oriented the air gap can be up to 35 mm, however mounting the switch or magnet on ferrous metal (steel) or rotating the magnet will reduce this range. Do not mount the switch/magnet assembly with steel in between.

Connect the plug from the seat switch to the plug on the alarm wiring harness. The switch has a self-adhesive backing to assist in mounting and is also supplied with screws if this method is preferred. If using the self-adhesive system, clean and de-grease the area thoroughly prior to fitting. Fit the magnet on the removable panel/seat adjacent to the switch using the fitting methods described above.

When correctly set; the switch should activate the alarm before the panel is removed by 50mm. The position of the switch/magnet should be adjusted accordingly to achieve maximum protection but to avoid false alerts.

If more than one area is to be protected, extra magnets and switches are available through Datatool, this is a chargeable extra. Extra magnets may also be needed if the pillion seat is used and the customer has a separate tailpiece. If several switches are to be used they must be run in series, not parallel. This method also applies to accessory loop protection where in-line connectors are positioned so soft luggage/accessories can be protected by running an extension wire through them and remaking the continuous trigger circuit.

### **The System LED Connections (orange and grey wires)**

The system LED provides the first line of defence as a visual deterrent and provides information regarding the status of the alarm system. Where possible agree the position for the system LED with the customer when discussing their requirements and fit it accordingly.

Do not fit more than one LED, it will increase the current usage of the system.

The LED can be installed by three methods:

- In its plastic bezel shroud via a drilled 8mm hole
- By an interference fit of the LED into an exact size hole drilled for the LED only (hole size 5mm)

A popular solution is to install the LED into the rear tail light or indicator for greater visual impact however with the current trend towards LED based rear light clusters it is very important the circuit board on the tail light is not damaged. It is unadvisable to drill the

back of the tail light of this design unless you are absolutely sure you will not damage the LED array. Often on this type of display it is possible to carefully drill the assembly so the alarm LED is fitted between the LED array and the lens of the tail light (normally at the top). When doing this, the LED wires themselves normally have to be bent over. Always position the LED so the wires can be bent in the right direction easily. Take care not to bend the LED wires over one another.

Connect the 2 pin plug on the LED to the 2 pin plug on the alarm wiring harness

**IMPORTANT:** The system LED is rated at 2 volts.

**DO NOT TEST IT ACROSS A 12 VOLT BATTERY – IT MAY EXPLODE!**

If you wish to test the LED directly use a 1.5v battery. The grey wire of the LED is positive the orange wire is negative

### **The Optional Supplementary Siren/pager Negative Output**

(green/yellow tagged wire)

The Green/Yellow tagged wire gives a maximum 100mA of 12v negative output only when the siren is sounding. This can be used to drive an additional siren, paging/text system or to activate a tracking system. Any such items are not part of the standard installation and therefore should be treated as extras and charged accordingly.

If you are not using this output the end of the wire should be insulated, the green/yellow tags should be left on and the wire stored safely in a suitable position.

12 Pin Connector (front view)



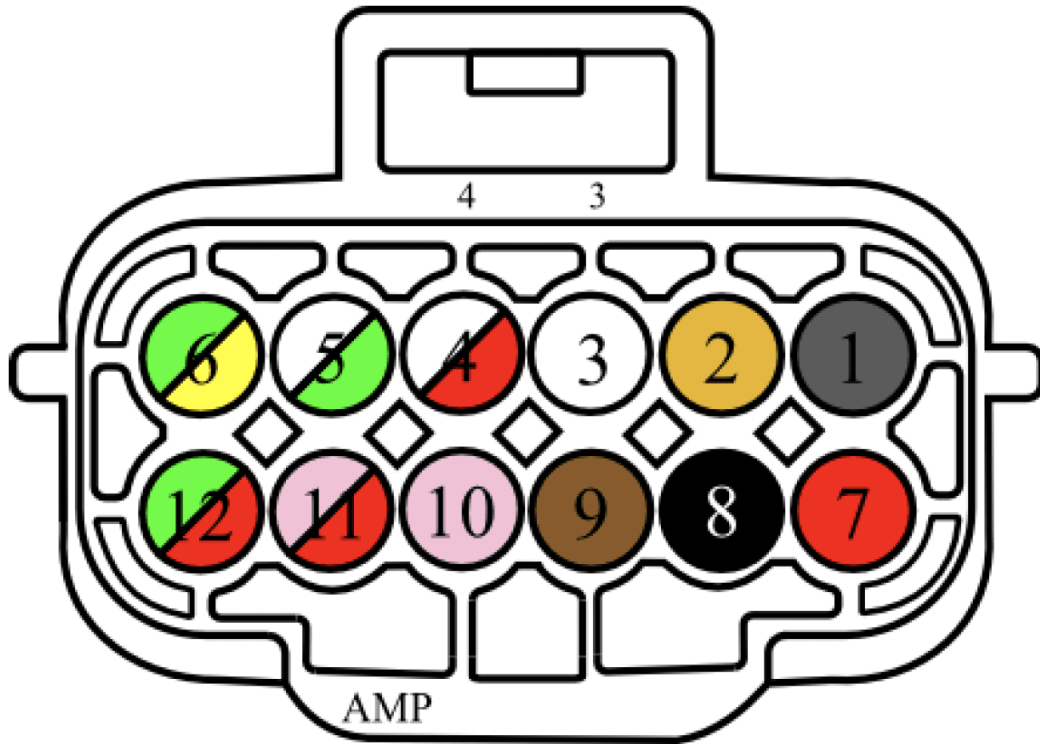

Connector harness fits directly to the mating alarm ECU harness, above diagram shows connector view only (looking at front Yellow connector support panel) all wiring locations are at rear of this connector.

<p><b>NOTE:</b> All cables between the alarm and alarm connector are black; except for the the led harness the colour description in the table below recognises the coloured ID tags of the mating harness. <b>Colour</b></p>	<p><b>Function</b></p>	
<b>Pin 1</b>	Grey	LED
<b>Pin 2</b>	Orange	LED
<b>Pin 3</b>	White	Engine common
<b>Pin 4</b>	White/Red	Engine normally closed

<b>Pin 5</b>	White/Green	Engine normally open
<b>Pin 6</b>	Green/Yellow	Aux trigger wire (Negative Output)
<b>Pin 7</b>	Red	Positive
<b>Pin 8</b>	Black	Ground & seat switch (2 wires on loom pin)
<b>Pin 9</b>	Brown	Ignition
<b>Pin 10</b>	Pink	Indicator
<b>Pin 11</b>	Pink/Red	Indicator
<b>Pin 12</b>	Green/Red	Seat Switch input (Neg)

## GET IN TOUCH

Our philosophy is simple- To provide the highest quality products covering everyday aspects of motorcycle and scooter security plus a range of accessories to make your life as a rider an easier one.

So, whatever you choose – scooter, cruiser, adventure, or sports bike, we're here to help keep you safe.

If you would like to know more information about our Datatool products or would like to get in touch. Please use our contact form below.



### CAPTCHA



I'm not a robot

reCAPTCHA

**SUBMIT**

## CONTACT DETAILS

Monday – Friday: 8:30 am – 5:00 pm

Telephone (General Enquiries): +44 (0)1257 249928

Email: [sales@datatool.com](mailto:sales@datatool.com)

PROUD TO BE MEMBERS OF



DATATOOL IS A BRAND OF SCORPION AUTOMOTIVE LTD

[TERMS & CONDITIONS](#) | [COOKIE POLICY](#) | SCORPION AUTOMOTIVE LTD 2022